

THE

# General Radio EXPERIMENTER



VOLUME XV No. 7

JANUARY, 1941

ELECTRICAL MEASUREMENTS AND THEIR INDUSTRIAL APPLICATIONS

<i>Also</i>	
IN THIS ISSUE	
	<i>Page</i>
NOTES ON CARE AND MAINTENANCE OF VARIACS.....	6

## A NEW NULL INSTRUMENT FOR MEASURING HIGH-FREQUENCY IMPEDANCE

● THE DESIGN of impedance-measuring equipment, in general, involves two fundamental choices, namely, the selection of an impedance standard, or standards, for comparison with the unknown impedance, and the selection of a method for indicating when a known relation between them is established.

It has been common experience that null methods of comparison yield the highest precision of setting. At commercial and audio frequencies, where there is relatively little difficulty in obtaining adequate impedance standards, bridge methods have therefore found almost

FIGURE 1. View of the TYPE 821-A Twin-T Impedance-Measuring Circuit with cover removed. The airplane-luggage type of case is provided with a carrying handle and the instrument is easily portable. Connecting cables and instruction book are mounted in the cover.

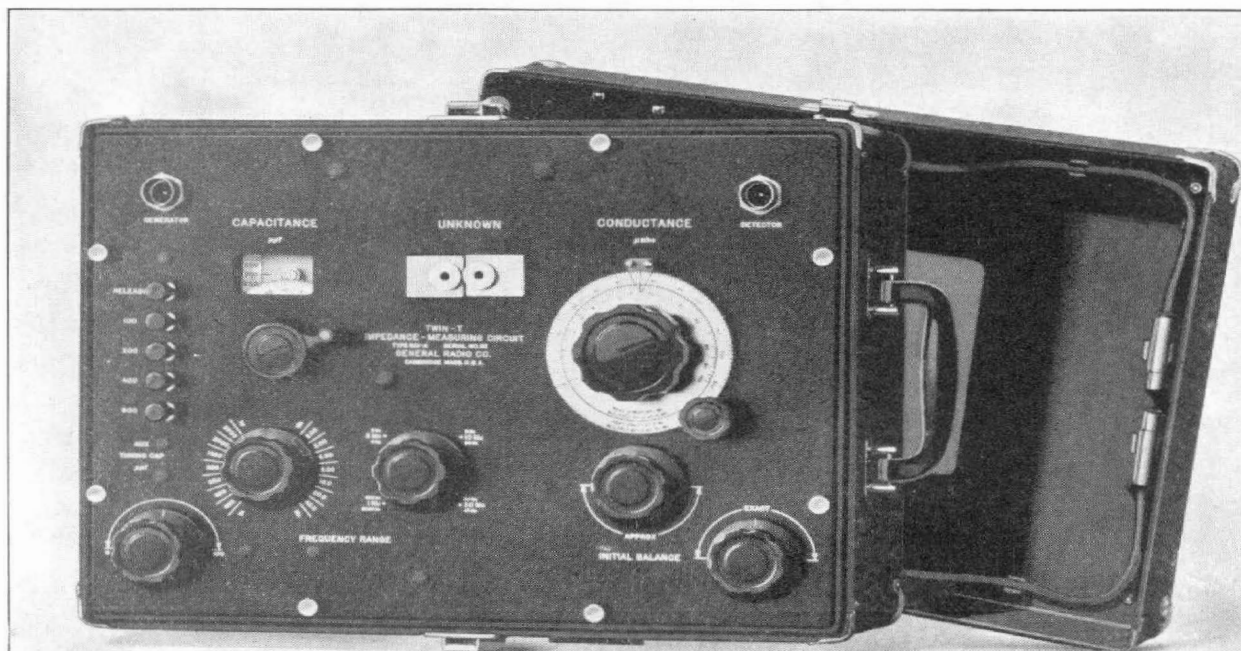

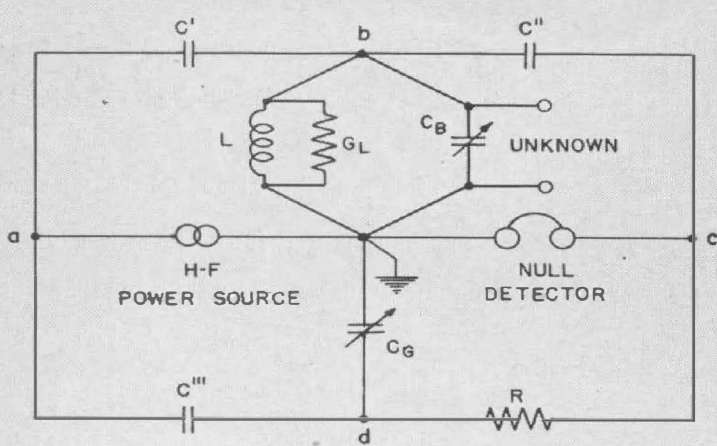

FIGURE 2. Basic circuit diagram of Twin-T impedance-measuring circuit. Losses in the tuning coil,  $L$ , are represented by the conductance,  $G_L$ , to simplify the balance equations.

universal acceptance. As the frequency is raised, however, residual parameters in the impedance standards and in the wiring cause more and more serious departures from idealized behavior, and, at radio frequencies, it is generally found that bridges designed for low-frequency operation become so inaccurate as to be useless.

Through proper choice of impedance standards and improvement in circuit configurations, the upper frequency limit for accurate bridge measurements has, in recent years, been progressively increased. This process of refinement, however, restricts more and more severely the choice of bridge circuits that can be used and thereby limits the convenience and adaptability that can be obtained.

Another approach to the problem of obtaining suitable null methods at high frequencies can be made by devising entirely different types of circuits rather than by refining existing bridge circuits. The new parallel-T circuits,<sup>1</sup> for instance, are generally adaptable for this service, and the TYPE 821-A Twin-T Impedance-Measuring Circuit, described in this article, uses one that has been found particularly satisfactory.<sup>2</sup>

<sup>1</sup>W. N. Tuttle, "Bridged-T and Parallel-T Null Circuits for Measurements at Radio Frequencies," Proc. I.R.E., Vol. 28, pp. 23-29, January, 1940.

<sup>2</sup>D. B. Sinclair, "The Twin-T. A New Type of Null Instrument for Measuring Impedance at Frequencies up to 30 Megacycles," Proc. I.R.E., Vol. 28, pp. 310-318, July, 1940.

## THEORY OF OPERATION

The basic circuit used is illustrated in Figure 2.

Balance is obtained when the transfer impedances<sup>3</sup> of the two parallel T-circuits  $a-b-c$  and  $a-d-c$  are made equal and opposite. For this condition the balance equations become:

$$G_L - R\omega^2 C' C'' \left( 1 + \frac{C_G}{C'''} \right) = 0 \quad (1)$$

$$C_B + C' C'' \left( \frac{1}{C'} + \frac{1}{C''} + \frac{1}{C'''} \right) - \frac{1}{\omega^2 L} = 0 \quad (2)$$

If the circuit is initially balanced to a null and then rebalanced by means of the condensers,  $C_G$  and  $C_B$ , when an unknown admittance,  $Y_x = G_x + jB_x$ , is connected to the terminals marked UNKNOWN in Figure 2, the unknown conductive and susceptive components can be found from

$$G_x = \frac{R\omega^2 C' C''}{C'''} (C_{G2} - C_{G1}) \quad (1a)$$

$$B_x = \omega(C_{B1} - C_{B2}) \quad (2a)$$

in which  $C_{G1}$  and  $C_{B1}$  represent capacitance values for initial balance, and  $C_{G2}$  and  $C_{B2}$  capacitance values for final balance.

## ADVANTAGES OF CIRCUIT

Used in this way, the circuit is seen to provide a parallel-substitution measurement of the unknown admittance, with the conductive component proportional to the incremental value of one variable air condenser and the susceptive component proportional to the incremental value of another air condenser. Since each balance is independent of the other, the circuit is well fitted for use in

<sup>3</sup>Defined as the ratio of the input voltage to the output current when the output terminals are short-circuited.

a direct-reading instrument for measuring admittance.

Two features of the circuit that make it particularly useful for measurements at radio frequencies are:

1. There is a common ground point for one side of the generator, one side of the detector, one side of the conductive-balance condenser,  $C_G$ , one side of the susceptive-balance condenser,  $C_B$ , and one side of the unknown admittance,  $Y_x$ . Not only does the common ground eliminate the need for the shielded transformer required in bridge circuits, but it renders innocuous many of the residual circuit capacitances, as can be seen from Figure 2. Capacitances from points  $a$  and  $c$  to ground, for instance, fall across the generator and detector where they cause no error. Capacitances from points  $b$  and  $d$  to ground fall across the susceptance-balance condenser,  $C_B$ , and the conductance-balance condenser,  $C_G$ . When substitution measurements are made in terms of capacitance increments they cancel out.

2. The conductive component is measured in terms of a fixed resistor and a variable condenser. This combination, providing the equivalent of a continuously variable resistance standard, has

been found much freer from residual parameters than any variable resistor yet devised.

These two features, in themselves, either minimize or eliminate certain unwanted residual parameters. The general circuit arrangement, in addition, disposes of others. Capacitance between points  $a$  and  $b$  of Figure 2, for instance, falls across condenser  $C'$ , capacitance between points  $b$  and  $c$  falls across condenser  $C''$ , and capacitance between points  $a$  and  $d$  falls across condenser  $C'''$ . These residual capacitances can all be included as parts of the various capacitances listed and taken into account in the instrument calibration.

### DESCRIPTION OF INSTRUMENT

Figure 4 is a panel view of the TYPE 821-A Twin-T Impedance-Measuring Circuit. The controls, shown in the photograph, are:

1. A precision-type variable air condenser used to measure susceptive components and having a dial directly calibrated from 100 to 1100  $\mu\mu\text{f}$ .
2. An auxiliary condenser, consisting of a bank of fixed condensers controlled

FIGURE 3. View of susceptance condenser  $C_B$  showing the two aluminum blocks used to feed from the stator to the internal circuit and to the panel terminal, and brass discs grounding the rotor to the frame through low-inductance brushes.

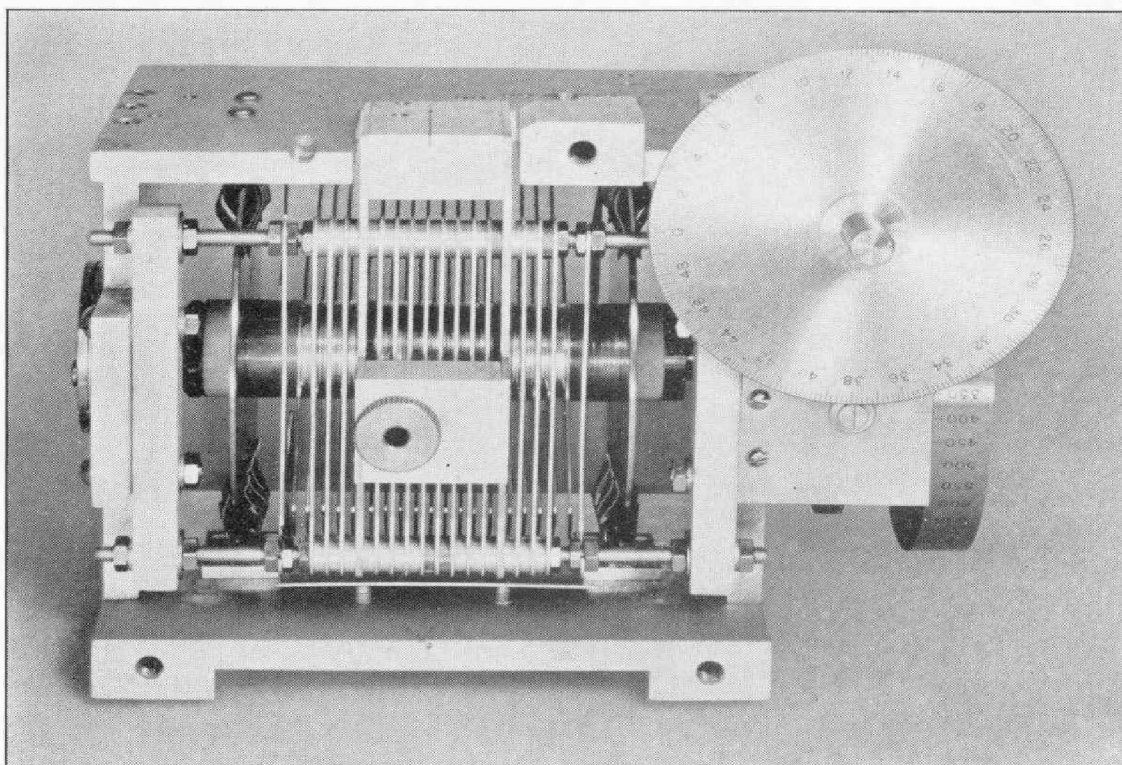



by push buttons and a small variable condenser, in parallel with the susceptance condenser, used to establish the initial susceptance balance at any chosen setting of the susceptance condenser.

3. A coil switch, marked with the frequency range covered by each tuning coil.

4. A variable air condenser used to measure conductive components and having two scales, one reading from 0 to 100  $\mu\text{mhos}$  and one reading from 0 to 300  $\mu\text{mhos}$ .

5. A 4-position switch used to establish a scale on the conductance dial from 0 to 100  $\mu\text{mhos}$  at 1 Mc, from 0 to 300  $\mu\text{mhos}$  at 3 Mc, from 0 to 1000  $\mu\text{mhos}$  at 10 Mc, and from 0 to 3000  $\mu\text{mhos}$  at 30 Mc. At other than these discrete frequencies, the dial reading must be multiplied by the square of the ratio of the frequency used to the nominal frequency indicated by the 4-position switch.

6. Two small variable condensers, in parallel with the conductance condenser, used as coarse and fine controls to establish the initial conductance balance at zero setting of the conductance condenser.

APPLICATION OF INSTRUMENT

Greatest convenience is obtained with the Twin-T in the measurement of admittances having relatively small conductive components since, for these measurements, the instrument is direct reading. By the use of series fixed condensers, however, admittances having relatively large conductance components can also be measured.

In the first class, namely, admittances having small conductive components, fall condensers, coils, dielectric samples, parallel-tuned circuits, high-resistance units, and antennas and unterminated transmission lines near half-wave resonance. In the second class, namely, admittances having large conductive components, fall series-tuned circuits, terminated transmission lines and matching sections, and antennas and unterminated transmission lines near quarter-wave resonance. Some typical measurements on a few of these devices will serve to indicate the general technique of measurement.

1. Measurement of a 500  $\mu\mu\text{f}$  condenser at 10 Mc.

Set the 4-position switch at 10 Mc and the coil switch on the 10.0-20.0 Mc

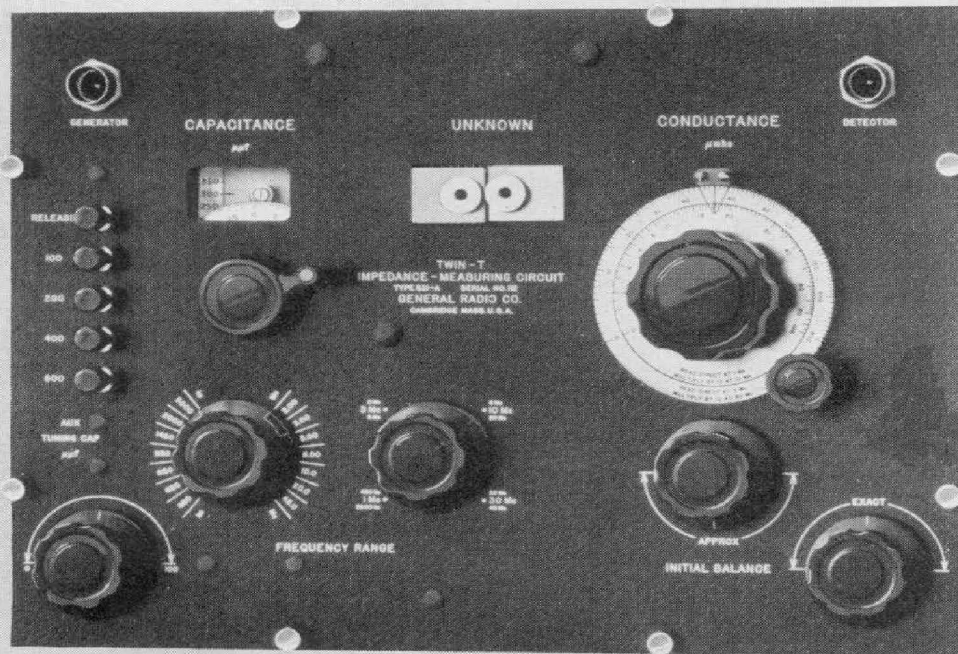

FIGURE 4. Panel view of experimental model of Twin-T impedance-measuring circuit. At the left of the panel are the susceptance condenser (CAPACITANCE  $\mu\mu\text{f}$ ) and the auxiliary tuning condenser (AUX. TUNING CAP.). At the right are the conductance condenser (CONDUCTANCE  $\mu\text{mho}$ ), and the parallel trimmer condensers (INITIAL BALANCE). The remaining controls (FREQ. RANGE) are the coil switch, at the left, and the conductance range switch, at the right.

range. Set the susceptance condenser at some high value, say 1000.0  $\mu\mu\text{f}$ , and the conductance condenser at zero. By varying the auxiliary condensers in parallel with the susceptance and conductance condensers, adjust to an initial balance.

Connect the condenser to be measured across the UNKNOWN terminals and, with the susceptance and conductance condensers, adjust to a final balance. Let the susceptance condenser setting be 442.4  $\mu\mu\text{f}$  and the conductance condenser setting be 80  $\mu\text{mho}$ .

Then the unknown parallel capacitance,  $C_x$ , and conductance,  $G_x$ , are:

$$C_x = 1000.0 - 442.4 = 557.6 \mu\mu\text{f}$$

$$G_x = 80 \mu\text{mho}$$

If it is desired to express the condenser loss in terms of dissipation factor,  $D_x$ :

$$D_x = \frac{G_x}{\omega C_x} = \frac{80 \times 10^{-6} \times 100}{2\pi \times 10^7 \times 557.6 \times 10^{-12}} = 0.23\%$$

### 2. Measurement of 1 $\mu\text{h}$ coil at 25 Mc.

Set the 4-position switch at 30 Mc and the coil switch on the 20.0–45.0 Mc range. Set the susceptance condenser at some low value, say 100.0  $\mu\mu\text{f}$ , and the conductance dial at zero. Establish the initial balance as described in the previous example.

Connect the coil to be measured across the UNKNOWN terminals and establish the final balance as before. Let the susceptance condenser setting be 139.8  $\mu\mu\text{f}$  and the conductance condenser setting be 90  $\mu\text{mho}$ .

Then the unknown susceptance,  $B_x$ , and conductance,  $G_x$ , are:

$$B_x = 2\pi \times 25 \times 10^6(100.0 - 139.8) \times 10^{-12} \times 10^6 = -6250 \mu\text{mho}$$

$$G_x = 90 \times \left(\frac{25}{30}\right)^2 = 62.5 \mu\text{mho}$$

The unknown parallel inductance,  $L_x$ , and storage factor,  $Q_x$ , can easily be found to be:

$$L_x = \frac{10^6}{2\pi \times 25 \times 10^6 \times 6250 \times 10^{-6}} = 1.02 \mu\text{h}$$

$$Q_x = \frac{6250}{62.5} = 100$$

### 3. Measurement of matched 72-ohm coaxial line at 830 kc.

Set the 4-position switch at 1 Mc and the coil switch on the 620–850 kc range. Establish an initial balance with the conductance condenser set at zero and the susceptance condenser at some value near mid-scale. Connect the impedance to be measured to the UNKNOWN terminals with a small "postage-stamp" type fixed condenser in series with the ungrounded lead. Change this series condenser to find the largest value for which a balance on the conductance dial can be obtained. Say this is 150  $\mu\mu\text{f}$ , nominal value.

Leave the ground terminal of the unknown impedance connected to the grounded UNKNOWN terminal. With the fixed condenser connected to the ungrounded UNKNOWN terminal, but free at the far end, establish an initial balance with the conductance condenser set at zero and the susceptance condenser at some relatively high value, say 500  $\mu\mu\text{f}$ .

Connect the free end of the series condenser,  $C_a$ , to the grounded UNKNOWN terminal and rebalance. If there is any appreciable change in conductance balance, rebalance with the zero-adjustment trimmers across the conductance condenser, leaving the conductance dial set at zero. Let the susceptance condenser reading be 352.5  $\mu\mu\text{f}$ . Then:

$$C_a = 500 - 352.5 = 147.5 \mu\mu f$$

$$X_a = \frac{-1}{2\pi \times 830 \times 10^3 \times 147.5 \times 10^{-12}} = -1300 \text{ ohms}$$

Disconnect the far end of the series condenser from the grounded UNKNOWN terminal and connect it to the ungrounded terminal of the unknown impedance. Rebalance with the susceptance and conductance condensers. Let their readings be 353.6  $\mu\mu f$  and 60.8  $\mu\text{mho}$ . Then the conductance and susceptance components of the series circuit are:

$$G = \left(\frac{0.83}{1}\right)^2 \times 60.8 = 41.9 \mu\text{mho}$$

$$B = 2\pi \times 830 \times 10^3 \times (500 - 353.6) \times 10^{-12} \times 10^6 = 764 \mu\text{mho}$$

Frequency Range: 420 kc to 30 Mc.  
 Capacitance Range: 100 to 1100  $\mu\mu f$  on standard condenser, direct reading.  
 Conductance Range:  
 0 — 100  $\mu\text{mho}$  at 1 Mc }  
 0 — 300  $\mu\text{mho}$  at 3 Mc } Direct Reading  
 0 — 1000  $\mu\text{mho}$  at 10 Mc }  
 0 — 3000  $\mu\text{mho}$  at 30 Mc }

Between these direct-reading ranges the range of the conductance dial varies as the square of the frequency.  
 Accuracy:  $\pm 1 \mu\mu f \pm 0.1\%$  for capacitance. For conductance,  $\pm 0.1\%$  of full scale  $\pm 2\%$  of actual dial reading.

Type	Code Word	Price
821-A	LAGER	\$340.00

## NOTES ON THE CARE AND MAINTENANCE OF VARIACS

● **MUCH INTEREST** has been shown in the recent article in the *General Radio Experimenter* which outlined a general maintenance and service program for General Radio instruments. A

From these figures, the resistance and reactance are:

$$R = \frac{41.9 \times 10^{-6}}{(764^2 + 41.9^2)10^{-12}} = 71.6 \text{ ohms}$$

$$X = \frac{-764 \times 10^{-6}}{(764^2 + 41.9^2)10^{-12}} = -1306 \text{ ohms}$$

The reactance of the line itself is found by subtracting the reactance of the series condenser:<sup>4</sup>

$$R_x = R = 71.6 \text{ ohms}$$

$$X_x = -1306 - (-1300) = -6 \text{ ohms}$$

— D. B. SINCLAIR

<sup>4</sup>The possibility of making substantial errors in reactance through taking the difference between two large numbers can be avoided by assuming that the conductance, *G*, is negligible compared with the susceptance, *B*, and taking the difference between the reactances corresponding to 147.5  $\mu\mu f$  and 146.4  $\mu\mu f$ . This gives a rough check figure of

$$X = \frac{10^{12}}{2\pi \times 830 \times 10^3} \left(\frac{146.4 - 147.5}{146.4 \times 147.5}\right) = -10 \text{ ohms}$$

**Accessories Supplied:** Coaxial cables for connections to generator and detector.  
**Accessories Required:** A suitable radio-frequency generator and detector are required. Either TYPE 684-A Modulated Oscillator (with the addition of a coaxial output jack) or TYPE 605-A Standard-Signal Generator is a satisfactory generator. A well shielded radio receiver covering the desired frequency range is recommended for the detector.  
**Mounting:** The instrument is mounted in an airplane-luggage type of case with carrying handle and removable cover.  
**Dimensions:** 17¾ x 12 x 9½ inches, over-all.  
**Net Weight:** 26 pounds.

number of requests for maintenance notes on particular instruments have now been received, and, because of the fact that over 35,000 Variacs are in use, it is believed that many customers

would welcome specific instructions for the maintenance of these controls.

Inspection of the Variacs returned for repairs shows such conditions as worn brushes and damaged windings to be most prevalent. Careful maintenance would have prevented most of this damage, with the exception of that caused by overloading.

The brushes should be inspected regularly to make certain that excessive wear has not taken place. The interval between inspections may be determined by the frequency at which the Variac voltage settings are changed. When the brush is worn the brass holder may come in contact with the winding surface and cause immediate fusing of the turns short-circuited by the holder. A worn brush may also cause arcing to the winding, and the resultant roughened areas on the contact surfaces will cause further wearing and damage to both the brush and the winding. It is recommended that a small stock of replacement brushes be ordered as part of the maintenance procedure.

Many Variacs are operated in locations where there is considerable dirt, dust, and grit, and even corrosive fumes. Such Variacs require frequent cleaning of the winding in order to insure positive contact between the brush and the winding. If this is not done, erratic operation may result, due to arcing and lack of proper contact, so that eventually the winding must be replaced.

When the surface on which the brush bears becomes blackened or corroded, it should be cleaned with crocus cloth or a very fine sandpaper, making certain that all rough places are smoothed. Remove the loose particles with a fine brush and then clean with carbon tetrachloride or some similar highly volatile cleaning agent.

Excessive heating usually will be

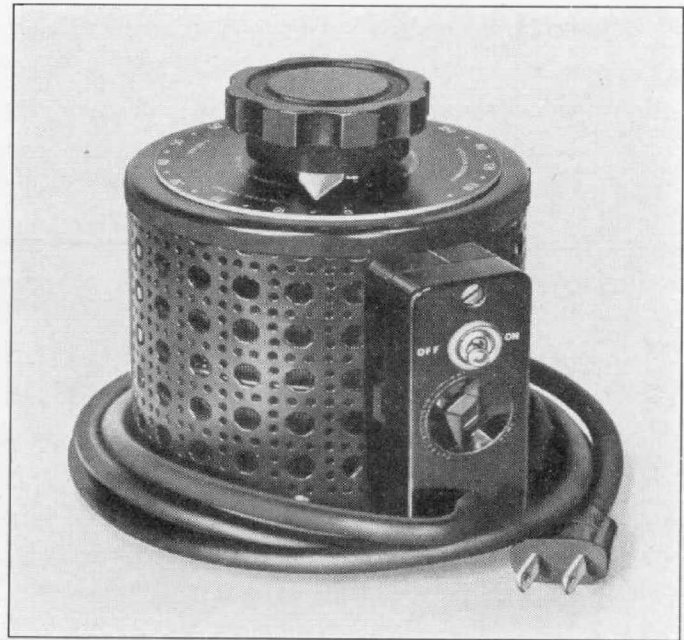

caused from too much current flowing in the load circuit. The portion of the winding affected depends in most instances upon the position of the brush. While the winding may not be damaged if the overload is removed quickly, the carbon of the brush may disintegrate. A new brush should be installed before the Variac is again placed in service.

Overheating the winding will cause the turns to loosen and, in cooling, they may not return to their original positions. A raised turn may cause a brush to wear excessively or even break.

The instructions that are included in every Variac shipment state that, when a Variac is used to control the voltage in the primary of a high-voltage transformer or other highly inductive load, it is necessary that either the voltage setting of the Variac be reduced to zero or the output circuit opened before the line circuit is broken. If neither of these procedures is followed, it is possible that a surge will cause serious damage to the winding, although each Variac is tested with 2000 volts d-c between the winding and the frame.

Since the Variac is an auto-transformer, it should never be connected to a load circuit containing a ground. The only exception is when one side of the line and one side of the load are both

grounded; these may be connected to the common input-output terminal of the Variac.

Adequate fusing in both line and load circuits is recommended. Replacement fuses are considerably cheaper than replacement Variacs. — H. H. DAWES

---

## MISCELLANY

● **AT THE ANNUAL BANQUET** of the Emporium Section, I.R.E., H.B. Richmond, Treasurer of the General Radio Company, was the guest speaker. His subject was "Observations of an Engineer on the Continent and in the Near East on the Threshold of War."

● **THE FOLLOWING ERRORS** occurred in the December issue of the *Experimenter*.

In the caption to FIGURE 3,  $R_0$  at 10 Mc should be 0.13  $\Omega$ .

In the caption to FIGURE 9, the values for  $R_0$  should be

0.004  $\Omega$  at 2 Mc

0.007  $\Omega$  at 5 Mc

0.01  $\Omega$  at 10 Mc

In the description of TYPE 318-C Dial Plate, it was stated that the scale progresses in a counterclockwise direction.

As the photograph clearly shows, the progression is clockwise. In addition, the photograph should show a nickel silver border around the dial, identical with that on TYPE 318-B.

● **EFFECTIVE JANUARY 1**, the price of the replacement TYPE 631-P1 Strobotron for use in TYPE 631-B Strobotac is reduced to \$4.50, net, f.o.b. Cambridge.

● **RECENT VISITORS** to the General Radio laboratories include Mr. W. J. Kroeger of the Frankford Arsenal, Mr. G. Forrest Drake, Chief Engineer of Woodward Governor Company, Dr. Frederick E. Termon, President of the Institute of Radio Engineers, and Messrs. W. R. Knotts, R. Howell, and F. R. Flansburg of RCA.

---

***THE General Radio EXPERIMENTER is mailed without charge each month to engineers, scientists, technicians, and others interested in communication-frequency measurement and control problems. When sending requests for subscriptions and address-change notices, please supply the following information: name, company name, company address, type of business company is engaged in, and title or position of individual.***

---

## GENERAL RADIO COMPANY

30 STATE STREET - CAMBRIDGE A, MASSACHUSETTS

BRANCH ENGINEERING OFFICES

90 WEST STREET, NEW YORK CITY

1000 NORTH SEWARD STREET, LOS ANGELES, CALIFORNIA